



CNO SERIES OFFSET SPANNER ATTACHMENTS

Experience zero-damage fastening with the innovative CNO Series! Its unique roller design eliminates scratches and dents, perfect for delicate applications like electronics and precision machinery. Save time and effort with the 3-in-1 convenience.



Zero-Damage Guarantee

The CNO Series boasts a unique roller design that eliminates scratches and dents, making it ideal for intricate applications involving electronics, precision machinery, and other delicate surfaces.

Built to Last & Perform

Each CNO spanner is meticulously crafted from high-strength steel to ensure unwavering durability. Additionally, ergonomic handles provide exceptional comfort, minimizing fatigue during prolonged use.

Unmatched Accuracy

Achieve flawless results with the CNO Series' precise fit and optional torque control mechanism (available on select models). This ensures you apply the exact amount of force required for each task, preventing over-tightening and potential damage.

TORQUE TOOLS



OPEN SPANNER

Ideal for accessing exposed nuts and bolts in tight spaces.



RING SPANNER

Offers superior grip and torque for even the most stubborn fasteners.



RATCHETING SPANNER

Enables fast, continuous operation, improving efficiency.

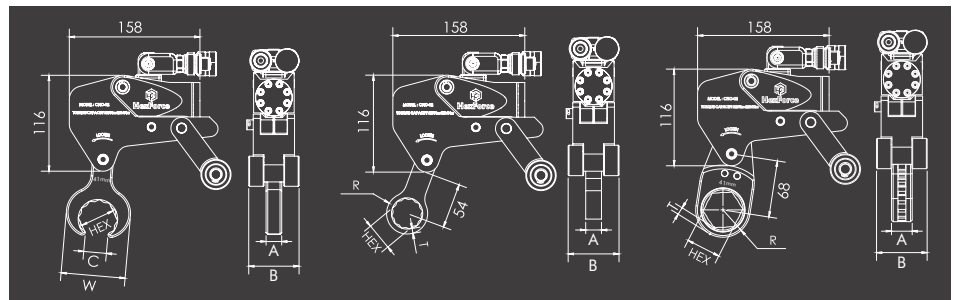

MODEL	HEX SIZE (mm)	TORQUE		OPEN SPANNER LINK (mm)				RING SPANNER LINK (mm)				RATCHET LINK (mm)			
		FT.LBS	NM	C	W	WIDTH		R	T	WIDTH		R	T	WIDTH	
						A	B			A	B			A	B
CNO-02	24	243 TO 1686	329 TO 2286	16.8	53.6	24	61	22.86	9.06	19	61	25.4	10.33	25.2	61
	27			18.8	58.05			22.86	7.34			25.4	9.88		
	32			22.9	64.8			24.65	6.25			27.43	9.03		
	36			24.9	71.5			27.43	6.73			29.97	9.27		
	41			27.9	79.8			31.24	7.67			32.77	9.20		
	46			30.7	93.5			34.8	8.35			35.56	9.11		
	50			36.8	94			38.61	9.29			41.15	11.83		
CNO-04	55	580 TO 3853	786 TO 5224	37	109.8	31	82.6	38.61	6.99	25.4	82.6	41.15	9.53	31	82.6
	41			27.2	77.9			32.8	9.19			33.8	10.21		
	46			30.2	92.9			35.6	9.11			36.8	10.32		
	50			33.5	90			38.4	9.60			39.2	10.44		
	55			36.1	108.9			41.1	9.52			42.3	10.63		
	60			39.9	108.9			45.0	10.46			45.5	10.98		
	65			55.60	114.00			46.7	9.36			48.7	11.35		
CNO-08	75	1142 TO 8146	1549 TO 11045	49.50	132.80	38	83	52.1	8.94	32	83	54.7	11.56	37.2	83
	50			33.1	110.4			40.13	11.38			44.2	15.45		
	55			36.1	115.4			42.93	11.3			46.99	15.37		
	60			39.1	120.4			45.72	11.22			49.78	15.28		
	65			43.7	127			48.51	11.14			52.58	15.2		
	70			46.7	133.6			51.31	11.06			55.37	15.12		
	75			49.7	146			54.36	11.23			58.42	15.3		
	80			53.3	152.6			57.15	11.15			61.21	15.21		
	85			58.1	162			60.2	11.32			64.26	15.39		
	90			61.5	163.3			62.99	11.24			67.06	15.31		
	95			65.3	172.4			66.04	11.42			70.1	15.48		
100	65.3	178	68.58	11.08	72.9	15.4									
105	69.1	188.9	71.48	11.4	75.8	15.5									